

WBHC-30670-000
SHT 1.1

NOTES:

 LOCATED FROM TWO SURFACES FOR CUSTOMER CONVENIENCE. ONLY APPLICABLE FROM ONE SURFACE, NOT TO BE USED TOGETHER.

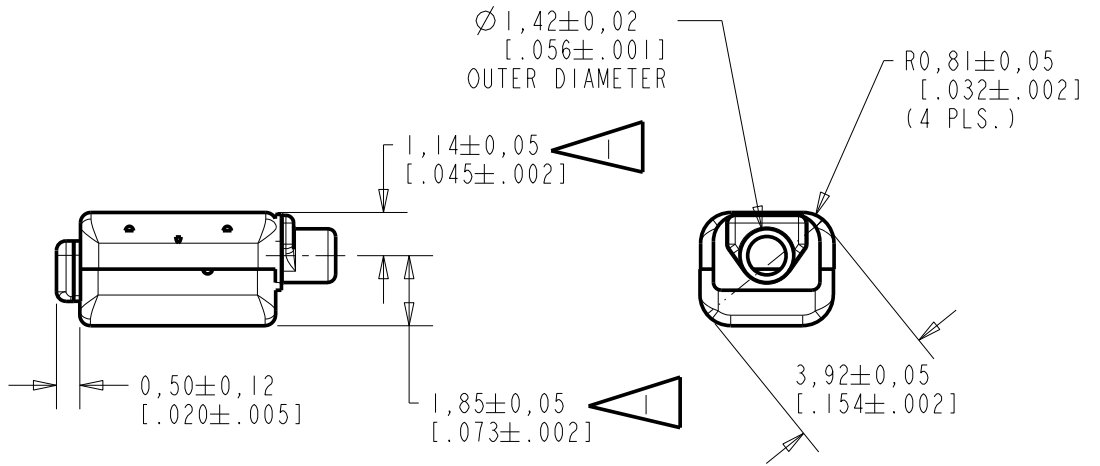
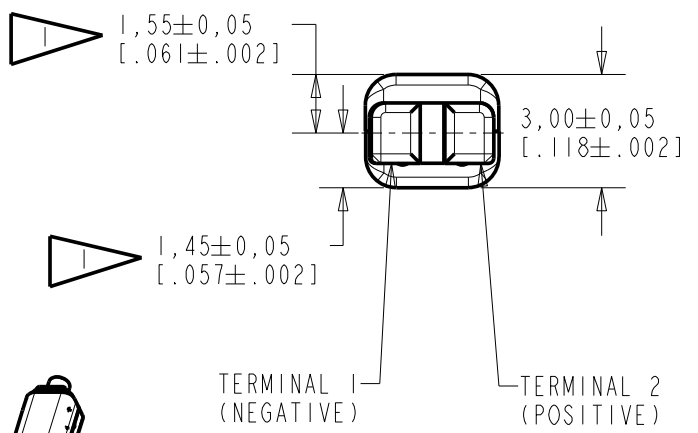
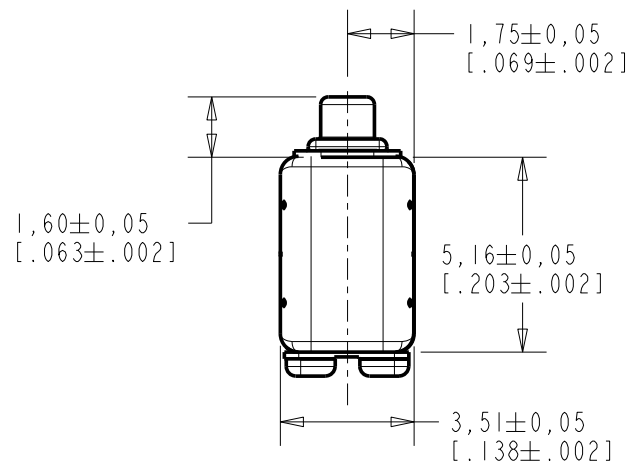

SCALE 2:1

NOMINAL WEIGHT
.21 GRAMS

DIMENSIONS IN MILLIMETERS [INCHES]

KNOWLES ELECTRONICS
ITASCA, ILLINOIS U.S.A.

Revision	C.O. #	Implementation Date	RELEASE LEVEL	REVISION
A	C10109548	5-06-09	Active	A

SCALE: 5:1		DR. BY: SDZ	DATE: 5-06-09
DO NOT SCALE DRAWING			
TITLE: RECEIVER		WBHC-30670-000	
OUTLINE DRAWING		SHT 1.1	
		APP. BY: GJP	DATE: 5-08-09
		APP. BY: GJP	DATE: 5-08-09

DESCRIPTION

NO DAMPING

WBHC-30670-000

SHEET 2.1

A MAGNETIC BALANCED ARMATURE RECEIVER INTENDED FOR USE IN ITC AND CIC HEARING INSTRUMENTS. THE WBHC FAMILY OFFERS AN EXTENDED HIGH FREQUENCY RESPONSE IN THE SAME SIZE PACKAGE AS THE HC FAMILY. ALL WBHC UNITS HAVE SHOCK PROTECTION. THIS MODEL HAS MEDIUM IMPEDANCE AND IS UNDAMPED.

NOTE: SPECIFICATIONS FOLLOWED BY AN ASTERISK (*) ARE 100% TESTED.

CONSTANT VOLTAGE DRIVE RESPONSE

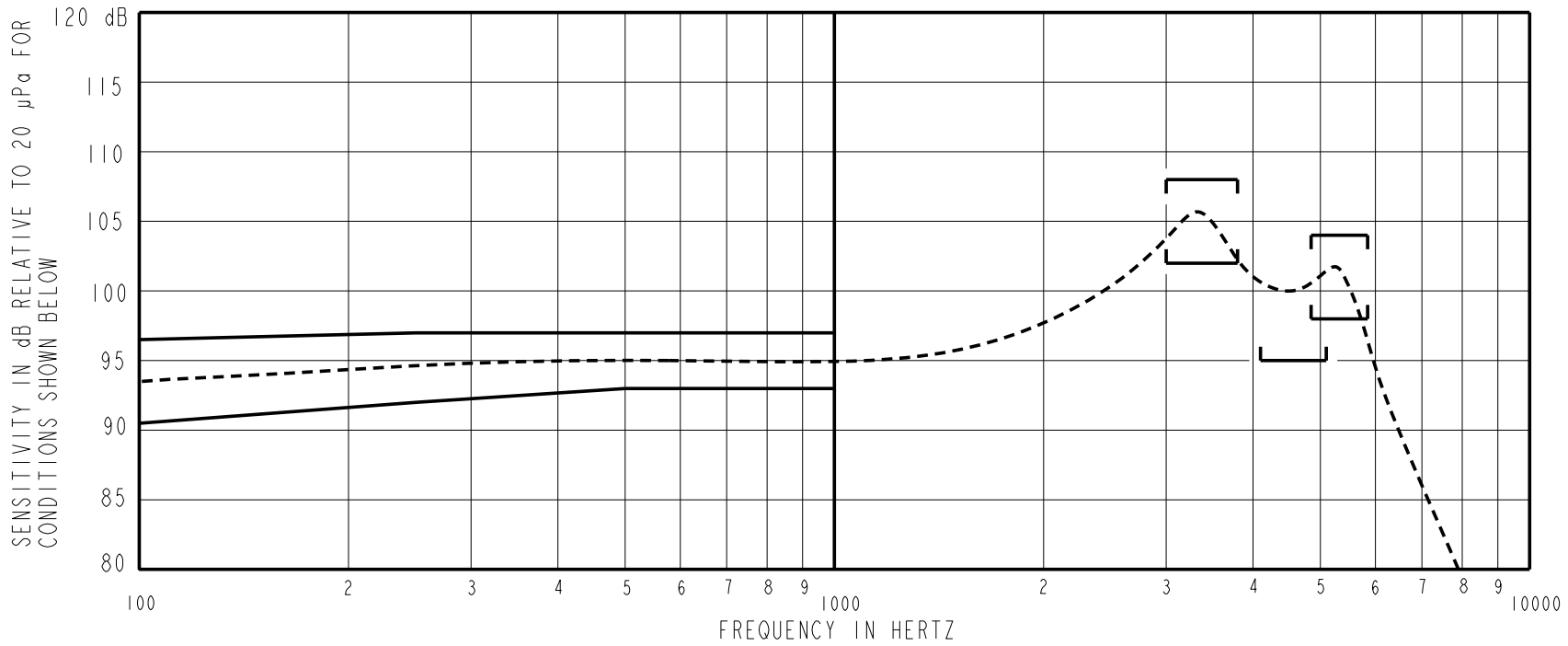

ACOUSTICAL

SENSITIVITY*
 DEVICE WILL PRODUCE THE SPL LISTED BELOW WITH THE TEST CONDITIONS DESCRIBED IN TABLE 3. NOMINAL SENSITIVITY AT 1 kHz IS dB RELATIVE TO 20µPa. ALL OTHER VALUES IN dB RELATIVE TO THE SENSITIVITY AT 1 kHz.

FREQUENCY (Hz)	MINIMUM	NOMINAL	MAXIMUM
100	-4.5	-1.5	+1.5
250	-3.0	-0.5	+2.0
500	-2.0	0.0	+2.0
1000	-2.0	95.0	+2.0
3000-3800 PEAK	+7.0	+10.0	+13.0
4100-5100 VALLEY	0.0	---	---
4850-5850 PEAK	+3.0	+6.0	+9.0

TABLE 1.

TOTAL HARMONIC DISTORTION*
 DEVICE WILL NOT EXCEED TOTAL HARMONIC DISTORTION LEVELS LISTED BELOW.

FREQUENCY (Hz)	DRIVE (V RMS)	DC BIAS (MA)	LIMIT (%)
1130	0.157 V	0	5
1700	0.157 V	0	5
500	0.858 V	0	10

TABLE 2.

TEST CONDITIONS

NOMINAL SOURCE VOLTAGE	0.157 Vrms, 0 Vdc BIAS
SOURCE IMPEDANCE	< 1 Ω
TUBING	10 mm (.394) LONG, 1 mm (.039) ID.
COUPLER CAVITY	2 CC SIMULATED ANSI S3.7 TYPE HA-3, (IEC 126)

TABLE 3.

POLARITY*
 POSITIVE SIGNAL APPLIED TO TERMINAL 2 WILL PRODUCE A DECREASE IN SOUND PRESSURE AT THE SOUND OUTLET.

ELECTRICAL

DC RESISTANCE	44 Ω ±10%	*
IMPEDANCE @ 500 Hz	46 Ω ±15%	*
IMPEDANCE @ 1 kHz	51 Ω ±20%	*
INDUCTANCE @ 500Hz	4 mH TYPICAL	
CAPACITANCE @ 10 MHz	4 pF TYPICAL	

TABLE 4.

ISOLATION: THE CASE WILL BE ELECTRICALLY ISOLATED FROM THE COIL CIRCUIT*

MAGNETIC RADIATION
 WORST CASE: FIELD WILL BE LESS THAN LEVEL STATED BELOW AT AMPLIFIER CLIPPING (.920 V).
 124 dB re 1µA/m
 DISTANCE OF 6.3 mm FROM CENTER OF RECEIVER
 ANGLE OF 45 DEGREES FROM TUBE

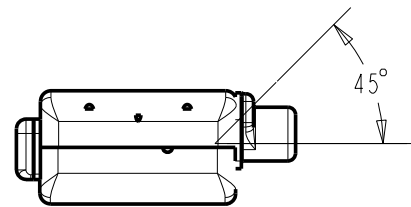

MECHANICAL

PORT LOCATION: 12C

SOLDER TYPE: SAC305

TEMPERATURE
 OPERATING: SENSITIVITY WILL NOT VARY MORE THAN +1/-3 dB FROM -17°C TO 63°C
 STORAGE: -40°C TO 63°C

KNOWLES ELECTRONICS
 ITASCA, ILLINOIS U.S.A.

Revision	C.O. #	Implementation Date	RELEASE LEVEL	REVISION
A	C10109548	5-06-09	Active	A

WHEN TEST LIMITS ARE USED TO ESTABLISH INCOMING INSPECTION ACCEPTANCE/REJECTION CRITERIA, CORRELATION OF TEST EQUIPMENT WITH KNOWLES IS ALSO REQUIRED FOR ELIMINATION OF EQUIPMENT AND TEST METHOD VARIATION		DR. BY	DATE
		SDZ	5-06-09
TITLE: RECEIVER		CK. BY	DATE
PERFORMANCE SPECIFICATION		GJP	5-08-09
WBHC-30670-000		APP. BY	DATE
SHT 2.1		GJP	5-08-09